

Tilt system | heavy duty



REAC Tilt base is compact and powerful. And can be customized to fit your application. Clever engineering allows tilt up to 50° with 250 kg load, still maintaining 91 mm overall build-in height. It has ideal specifications for electrical wheelchairs as well as other suitable applications.

The standard configuration includes easy adaptable top- and bottom frames. The motion is powered by a Reac actuator which can be controlled by any Reac control device as well as the market standard controllers. Tilt movement includes standard built-in actuator limit switch and optional inhibit switch for end limit detection and optional analogue positioning feedback.

We offer to customize to match your needs, please contact our sales department in case of any questions

Heavy duty features

| | |
|---------------------|--------------------------|
| Load capacity | 250kg |
| Min install height | 91mm |
| Tilting angle | 0° - 50° |
| Weight | 15kg |
| Feedback & switches | Limit switch in actuator |
| Motor | 24VDC |
| Actuator | RE5003 |

Options

| | |
|-----------------------|---|
| Top and bottom frame | Customized |
| Feedback and switches | Limit switch in actuator, built in potentiometers, hall sensors and inhibit switches. |
| Motor | 12VDC |



Tilt system

Dimensions

Heavy duty Tilt system

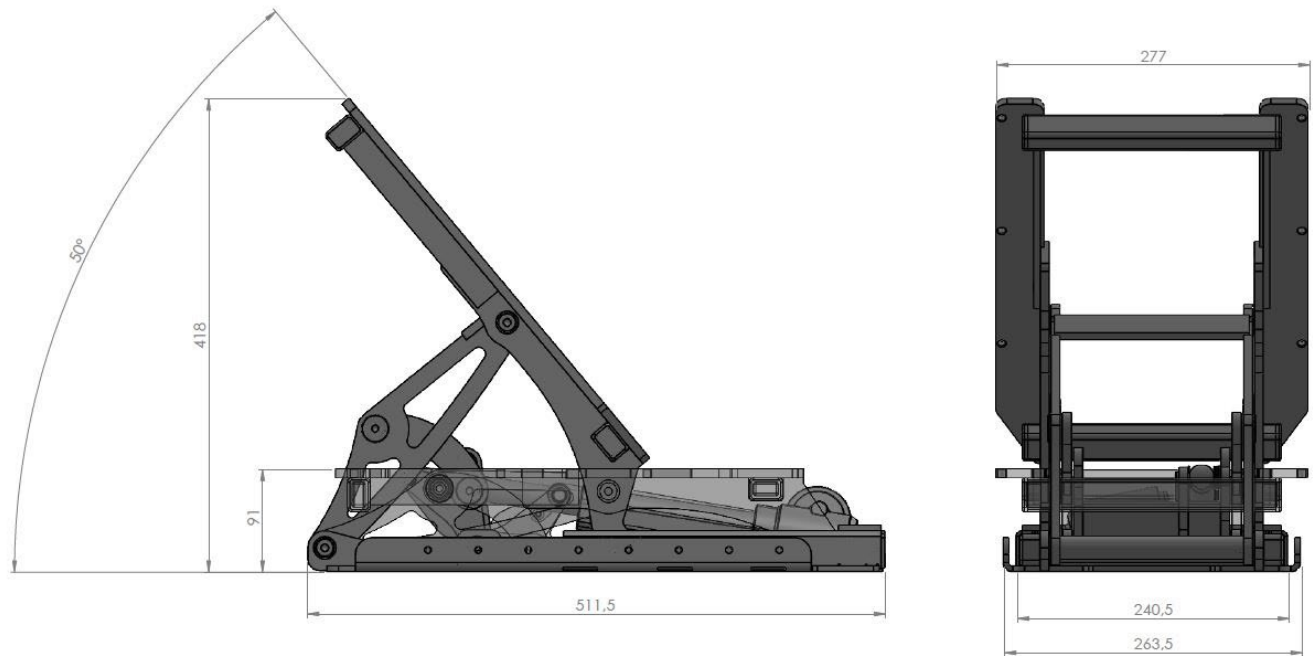

© REAC, August 2023, Issue 3.2

REAC is continuously developing our products and can make changes without prior notice. Therefore we can't guarantee that the information stated on our webpage or in our written material always is up to date, nor can we take responsibility for any misinterpretation of our written context. Technical specification might change due to load and external circumstances. REAC products shall be tested in its intended application before use.

REAC AB
J A Wettergrens gata 7
421 30 Västra Frölunda, Sweden

REAC Poland Sp. z o.o
Metalowców 10
97-300 Piotrków Trybunalski, Poland

www.reac-group.com
E-mail: info@reac-group.com
Phone: +46 31 350 99 00